



KiddiKart

Storage and Shelving for Early Childhood Centres.

Creating a dynamic versatile and flexible space for early childhood learning centres and primary schools is key to enabling optimum teaching and learning environments. The KiddiKart range has been designed to store classroom toys, teaching aids and children's belongings.

The units are low in height to enable interaction and visibility across a space. The mobility of the units assists the educators to divide the space based on activities and needs throughout the day. Planex's KiddiKart range is manufactured from 100% recyclable Australian steel.

Manufacturer	Planex Sales Pty Ltd
Location	Hallam, Melbourne
Standard Warranty	Ten years

KiddiKart Dimensions

Code	Description	Height	Width	Depth
12-KK-TYP-A	16 Bays (8 sml 8 lge)	1050	1450	500
Internal	Small	160	335	482
	Large	270	335	482
12-KK-TYP-B	16 Bays (16 sml)	850	1450	500
Internal	One size	167	335	482
12-KK-TYP-C	6 Bays (offset)	850	1200	500
Internal	Small	326	267	482
	Large	326	557	482
12-KK-TYP-D	4 Doors (cam lock)	850	1200	500
Internal	One size	707	267	482
12-KK-TYP-E	8 Doors (push latch)	850	1200	500
Internal	One size	326	267	482

* Storage tubs not included with KiddiKart unit

Materials

- Welded body made of 100% recyclable BlueScope sheet steel (with 24.2% recycled content)

Colours/Finishes

- Standard powder coats available in 300+ colours/finishes

Product Features

- Italian 50mm castors



- Door hinges
- Push latch mechanism, cam lock or rotary hasp (padlock not included) on doors



Manufacturing

- Made in Melbourne, Australia using locally sourced materials
- Manufactured for disassembly
- Polymer parts labelled for segregation and sorting
- Iron phosphate pre-treatment AS2331.3.1-2001 Method 3.1
- Planex factory uses a 100kW roof mounted solar array to provide up to 25% of manufacturing electricity needs

Environmental Certification

- Certified Furntech-AFRDI Blue Tick AS/NZS 4610.3:2020 Furniture-School and Educational, Part 3: Storage furniture-Strength, durability and stability
- Product may contribute to Green Star credit points
- VOC compliant materials

Designed by Planex

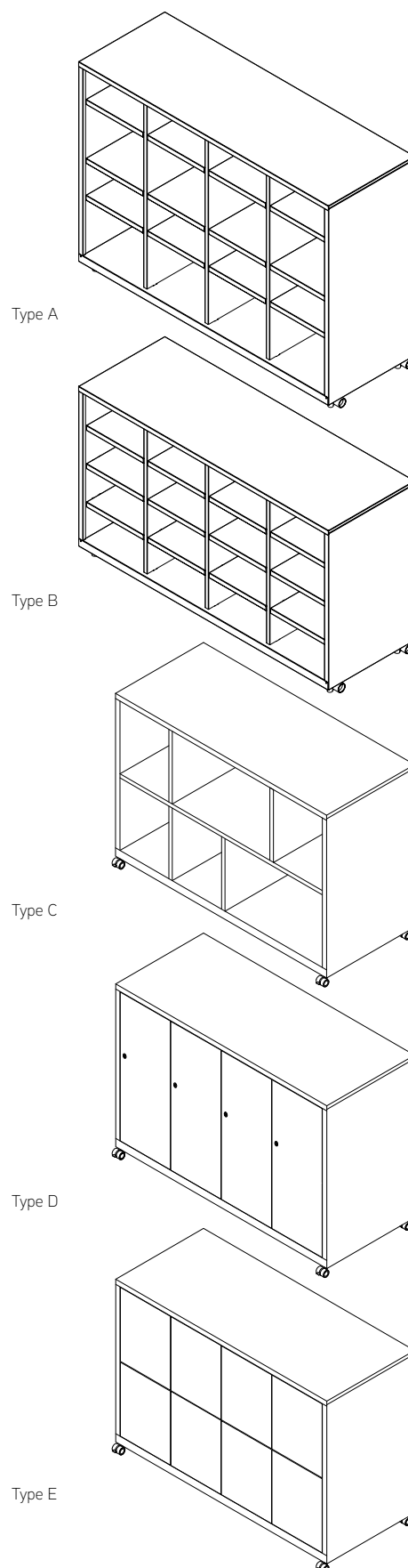



Copyright Planex 2023

Information in this document may be
subject to change without notification

Head Office / Manufacturing

191 Princes Highway Hallam

VIC Australia 3803

PO Box 125 Hallam 3803

Tel: +61 3 8795 1100

Fax: +61 3 8795 1122

Email Head Office: info@planex.com.au

National Sales and Distribution

Adelaide

Brisbane

Canberra

Hobart

Perth

Sydney

Tel: +61 3 8795 1100

Email: info@planex.com.au

www.planex.com.au