



S-Series SM Mobile Tambour Aluminium

A streamlined storage solution on castors, made to the high quality standards you have come to expect.

Offering flexibility within a general-purpose office storage cabinet, the S-Series Mobile Tambour Door Cabinet features castors and retractable doors making it suitable for high-traffic areas with restricted space. The original Planex storage range, S-Series is a classic and flexible storage solution designed to meet the demands of the modern office.

Manufacturer	Planex Sales Pty Ltd
Location	Hallam, Melbourne
Standard Warranty	Ten years

S-Series Dimensions

SM Mobile Tambour PP 900W	Height	Width	Depth
21-SM0670AL-0900-C80	770	900	500
21-SM0700AL-0900-C80	800	900	500
21-SM0800AL-0900-C80	900	900	500
21-SM1000AL-0900-C80	1100	900	500
21-SM1200AL-0900-C80	1300	900	500

SM Mobile Tambour PP 1200W	Height	Width	Depth
21-SM0670AL-1200-C80	770	1200	500
21-SM0700AL-1200-C80	800	1200	500
21-SM0800AL-1200-C80	900	1200	500
21-SM1000AL-1200-C80	1100	1200	500
21-SM1200AL-1200-C80	1300	1200	500

Materials

- Welded body made of 100% recyclable BlueScope sheet steel (with 24.2% recycled content)
- Aluminium doors

Colours/Finishes

- Standard powder coats available in 300+ colours/finishes
- Aluminium doors (AL) available in up to 300+ colours subject to finish suitability

Product Features

- 80mm diameter European castors (lockable)
- Flush internal wall
- European locking system with interchange barrel locks (1000 random combinations)
- No assembly required

Accessories Ordered Separately

- Adjustable shelves
- Shelf dividers
- Rails to hold L'Oblique TUB folders (hook folders)
- Shelf wire rack dividers for lateral shelf files (wrap around and square)
- Master keys and option to key-alike available

Manufacturing

- Made in Melbourne, Australia using locally sourced materials
- Manufactured for disassembly
- Polymer parts labelled for segregation and sorting
- Iron phosphate pre-treatment AS2331.3.1-2001 Method 3.1
- Planex factory uses a 100kW roof mounted solar array to provide up to 25% of manufacturing electricity needs

Environmental Certification

- GECA certified
- Product may contribute to Green Star credit points
- Production facility certified ISO14001 and ISO9001
- VOC compliant materials

Designed by Planex

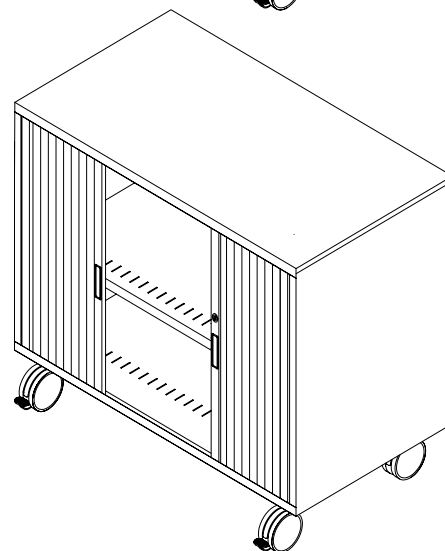
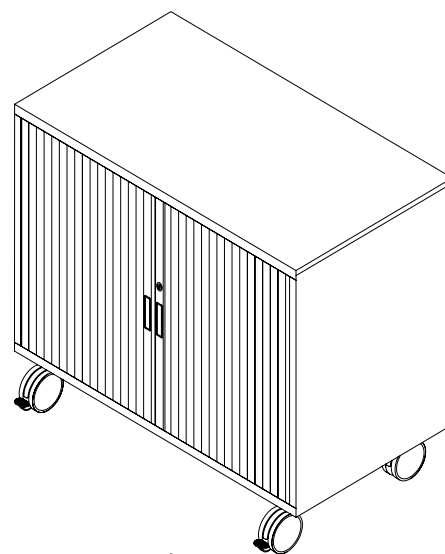

S-Series Accessories

Adjustable Shelf	Height	Width	Depth	Size
22-SHU-0900	25	755	450	900
22-SHU-1200	25	1055	450	1200

Shelf Divider	Height	Width	Depth	Size
22-SHUU-DIV	135	1	410	all

Wrap Around Toast Rack	Height	Width	Depth	Size
26-RACK-0900	200	735	400	900
26-RACK-1200	200	1035	400	1200

Square Toast Rack	Height	Width	Depth	Size
26-RACK-0900SQ	210	735	300	900
26-RACK-1200SQ	210	1035	300	1200

Lateral Rail Assembly	Height	Width	Depth	Size
24-FRAD2-0900	n/a	n/a	n/a	900
24-FRAD2-1200	n/a	n/a	n/a	1200

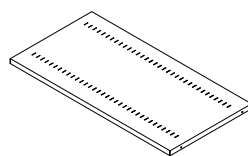

Adjustable Shelf

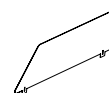

Shelf Divider

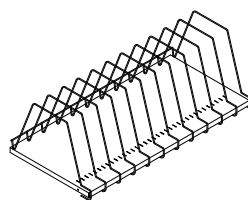

Wrap Around Toast Rack

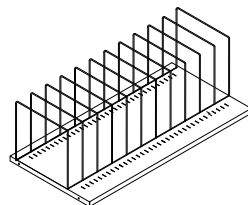

Square Toast Rack

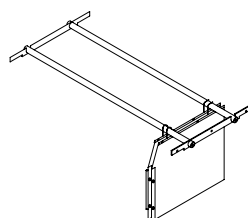

Lateral Rail Assembly



Copyright Planex 2023

Information in this document may be
subject to change without notification

Head Office / Manufacturing

191 Princes Highway Hallam

VIC Australia 3803

PO Box 125 Hallam 3803

Tel: +61 3 8795 1100

Fax: +61 3 8795 1122

Email Head Office: info@planex.com.au

National Sales and Distribution

Adelaide

Brisbane

Canberra

Hobart

Perth

Sydney

Tel: +61 3 8795 1100

Email: info@planex.com.au

www.planex.com.au